

8 7 6 5 4 3 2 1

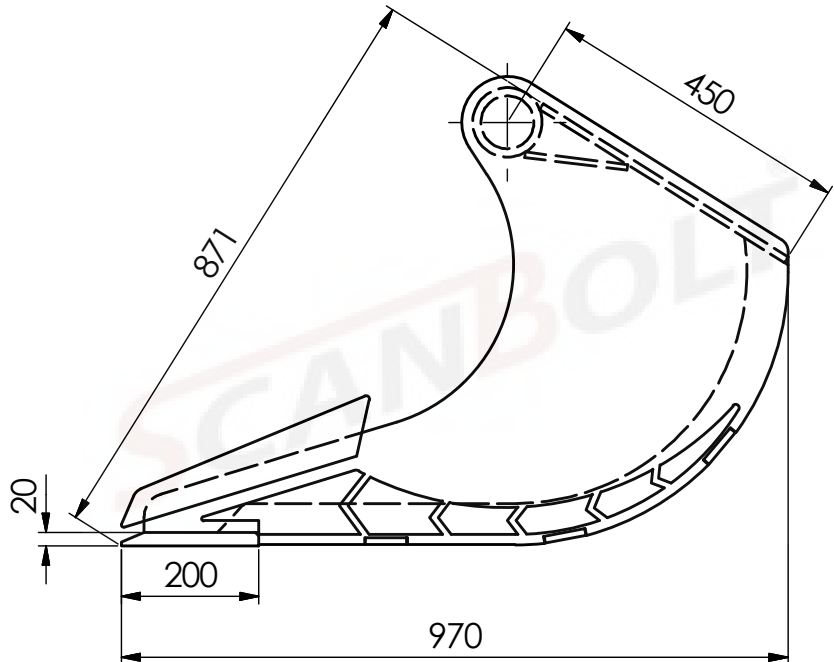
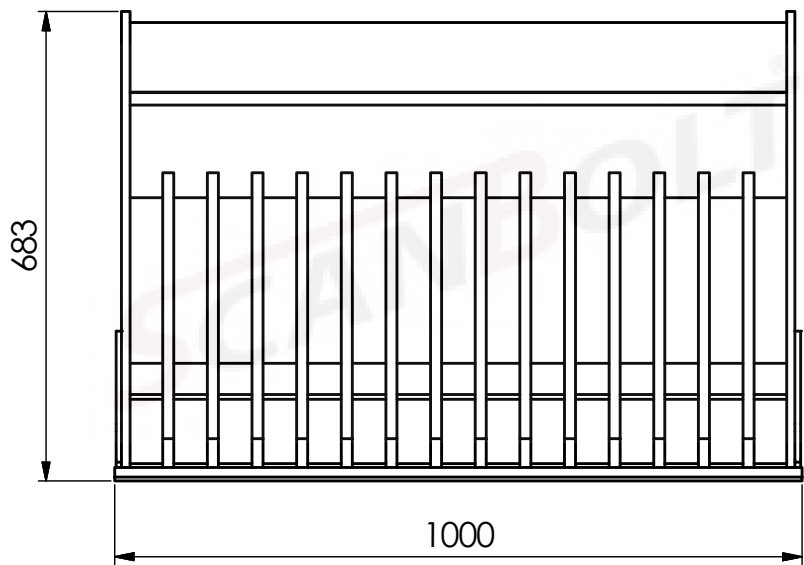
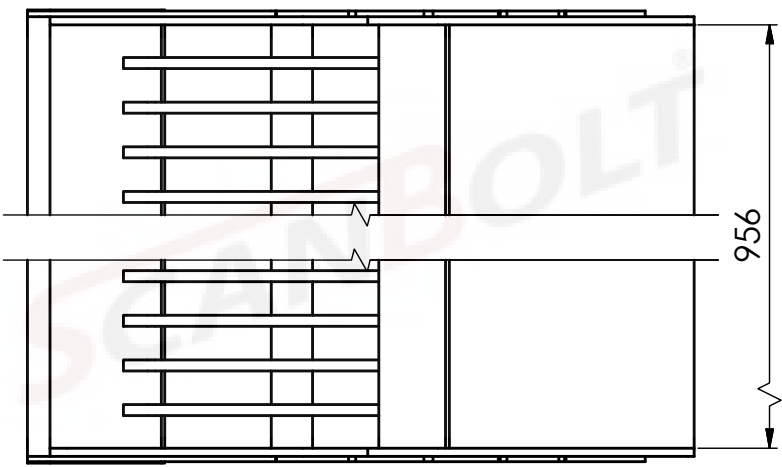
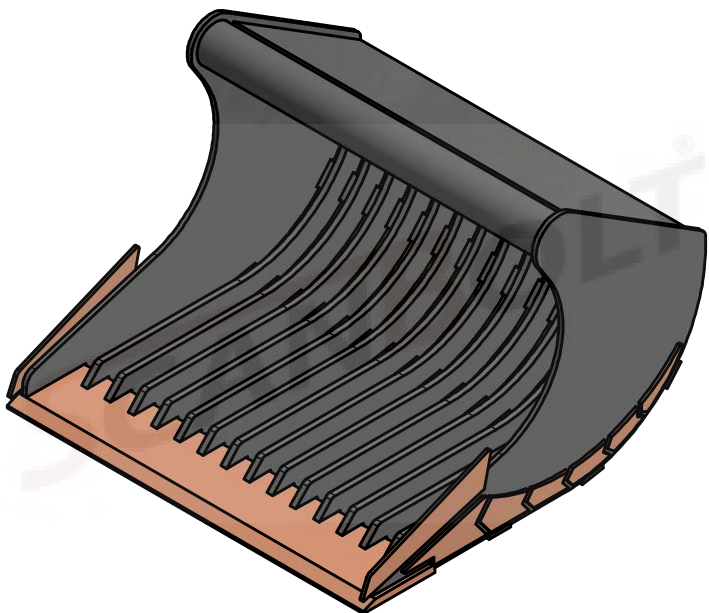

MATERIAL SPECIFICATION	
ST52.3	Grey
EN8D	Pink
HB 400	Light Orange
HB 450	Dark Orange
CASTALLOY STEEL	Yellow

SCANBOLT®	
DESCRIPTION	100CM RIDDLE BUCKET
MACHINE CLASS	7.5 - 10 TON
WEIGHT	283 Kg
HEAPED CAPACITY	402 LITERS

8 7 6 5 4 3 2 1